



# Power Clear® 518 ZR Snowthrower

Model No. 38472—Serial No. 316000001 and Up

Model No. 38473—Serial No. 316000001 and Up

## Operator's Manual

## Introduction

### ⚠ WARNING

#### CALIFORNIA Proposition 65 Warning

This product contains a chemical or chemicals known to the State of California to cause cancer, birth defects, or reproductive harm.

The engine exhaust from this product contains chemicals known to the State of California to cause cancer, birth defects, or other reproductive harm.

This machine is intended to be used by residential homeowners. It is designed primarily for removing snow from paved surfaces, such as driveways and sidewalks, and other surfaces for traffic on residential or commercial properties. It is not designed for removing materials other than snow, nor is it designed for clearing off gravel surfaces.

**Note:** The machine may leave rubber marks on new brushed or light-colored concrete. Test on an inconspicuous location before use.

Read this information carefully to learn how to operate and maintain your product properly and to avoid injury and product damage. You are responsible for operating the product properly and safely.

You may contact Toro directly at [www.Toro.com](http://www.Toro.com) for product and accessory information, help finding a dealer, or to register your product.

Whenever you need service, genuine Toro parts, or additional information, contact an Authorized Service Dealer or Toro Customer Service and have the model and serial numbers of your product ready. [Figure 1](#) identifies the location of the model and serial numbers on the product. Write the numbers in the space provided.

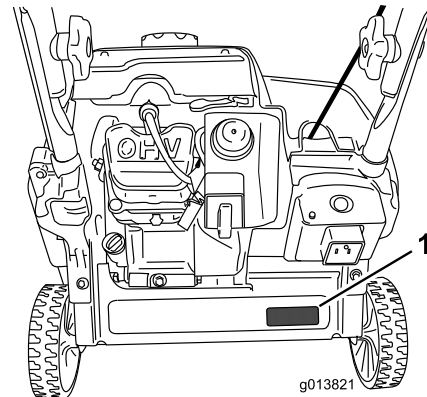

**Figure 1**

1. Model and serial number location

Model No. \_\_\_\_\_

Serial No. \_\_\_\_\_

This manual identifies potential hazards and has safety messages identified by the safety-alert symbol ([Figure 2](#)), which signals a hazard that may cause serious injury or death if you do not follow the recommended precautions.



**Figure 2**

1. Safety-alert symbol

This manual uses 2 words to highlight information.

**Important** calls attention to special mechanical information and **Note** emphasizes general information worthy of special attention.



# Contents

Introduction .....	1
Safety .....	2
Safety and Instructional Decals .....	3
Setup .....	4
1 Installing the Handle .....	4
2 Installing the Recoil-Starter Handle .....	4
3 Installing the Discharge Chute .....	5
4 Filling the Engine with Oil.....	5
5 Adjusting the Control Cable .....	6
Product Overview .....	7
Operation .....	8
Before Operation .....	8
Safety.....	8
Filling the Fuel Tank .....	8
Checking the Engine-Oil Level.....	8
During Operation .....	9
Safety.....	9
Starting the Engine .....	10
Engaging the Rotor Blades.....	11
Disengaging the Rotor Blades .....	11
Stopping the Engine .....	12
Adjusting the Discharge Chute and Chute Deflector.....	12
Clearing a Clogged Discharge Chute .....	12
Self-propelling the Snowthrower .....	12
Operating Tips .....	13
After Operation .....	13
Safety.....	13
Preventing Freeze-up after Use.....	13
Maintenance .....	14
Recommended Maintenance Schedule(s) .....	14
Maintenance Safety.....	14
Adjusting the Control Cable.....	14
Inspecting the Rotor Blades .....	14
Changing the Engine Oil .....	14
Servicing the Spark Plug .....	15
Replacing the Drive Belt.....	17
Storage .....	18
Storing the Machine.....	18

# Safety

**This machine meets or exceeds the B71.3 specifications of the American National Standards Institute in effect at the time of production.**

- Read and understand the contents of the manual before you start the engine. Make sure everyone using this product knows how to use the product and understands the warnings.
- Do not put hands or feet near moving components on the machine.
- Do not operate machine without all guards and other safety protective devices in place and working on the machine.
- Keep clear of any discharge opening. Keep bystanders a safe distance from the machine.
- Keep children out of the operating area and under the watchful care of a responsible adult other than the operator. Never allow children to operate the machine.
- Shut the machine off before unclogging, servicing, or fueling.

# Safety and Instructional Decals

**Important:** Safety and instruction decals are located near areas of potential danger. Replace damaged decals.

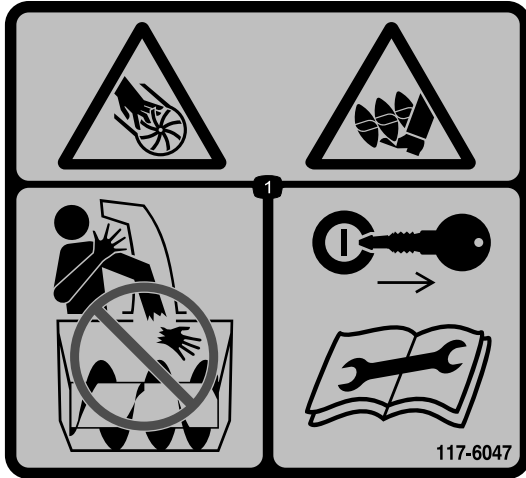

117-6047

1. Cutting dismemberment, impeller and cutting dismemberment, auger hazards—do not place your hand in the chute; remove the ignition key and read the instructions before servicing or performing maintenance.

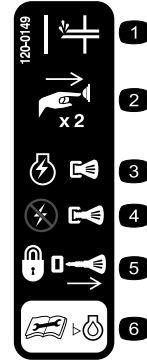

120-0149

1. Primer
2. Push the primer two times to prime the engine.
3. Push key in to switch engine on.
4. Pull key to switch engine switch off.
5. Remove key to lock machine.
6. Read the *Operator's Manual* before checking engine oil level.



117-7713

1. Warning—read the *Operator's Manual*.
2. Cutting/dismemberment hazard, impeller—stop the engine before leaving the machine.
3. Thrown object hazard—keep bystanders a safe distance from the machine.
4. Fuel spill hazard—do not tip machine forward or backward.
5. To engage the auger, squeeze the control bar.
6. Release the control bar to disengage the auger.

# Setup

## Loose Parts

Use the chart below to verify that all parts have been shipped.

Procedure	Description	Qty.	Use
<b>1</b>	Oval-head bolts Curved washers Handle knobs	2 2 2	Install the handle.
<b>2</b>	No parts required	–	Install the recoil starter handle.
<b>3</b>	Discharge chute Screws Washers Locknuts Knob	1 2 2 2 1	Install the discharge chute.
<b>4</b>	Bottle of engine oil	1	Fill the engine with oil.
<b>5</b>	No parts required	–	Adjust the control cable.

# 1

## Installing the Handle

### Parts needed for this procedure:

2	Oval-head bolts
2	Curved washers
2	Handle knobs

### Procedure

1. Position the ends of the upper handle on the inside of the lower handle and align the holes.
2. Insert the oval-head bolts into the aligned holes, with the bolt heads on the outside of the handle (Figure 3).

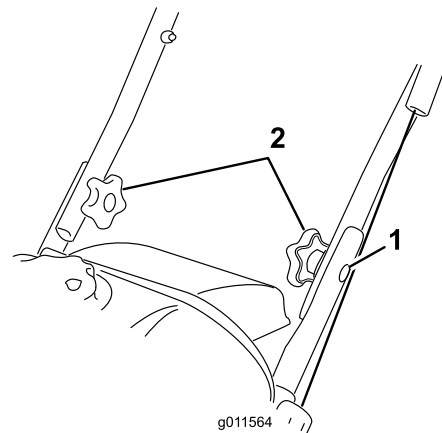

**Figure 3**

1. Oval-head bolt (2)
  2. Curved washers and handle knobs
- 
3. Install the curved washers and the handle knobs on the oval-head bolts on the inside of the handle (Figure 3) and **tighten the knobs securely**.

**Important:** Ensure that the cable is routed to the outside of the handle.

# 2

## Installing the Recoil-Starter Handle

No Parts Required

### Procedure

Install the recoil-starter handle in the rope guide as shown in [Figure 4](#).

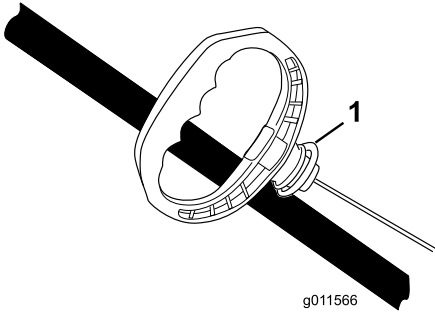

Figure 4

- 1. Rope guide

# 3

## Installing the Discharge Chute

Parts needed for this procedure:

1	Discharge chute
2	Screws
2	Washers
2	Locknuts
1	Knob

### Procedure

Install the discharge chute as shown in [Figure 5](#).

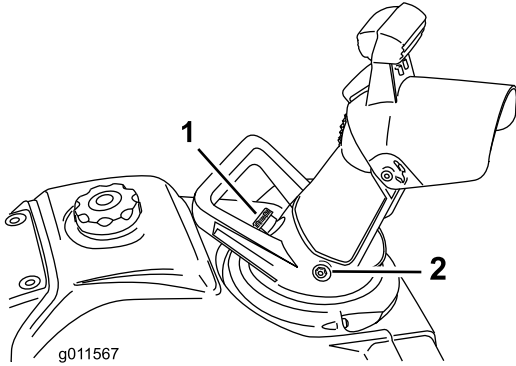

Figure 5

- 1. Knob
- 2. Bolt (2), washer (2), and locknut (2)

**Note:** Install the bolts from the inside of discharge chute assembly so that the washers and locknuts are on the outside of the chute.

**Important:** Do not overtighten the locknuts.

# 4

## Filling the Engine with Oil

Parts needed for this procedure:

1	Bottle of engine oil
---	----------------------

### Procedure

Your machine does not come with oil in the engine, but it does come with a bottle of oil.

**Important:** Before starting the engine, fill the engine with oil.

Max fill: 0.35 L (12 oz), type: automotive detergent oil with an API service classification of SJ, SL, or higher.

Use [Figure 6](#) to select the best oil viscosity for the outdoor temperature range expected:

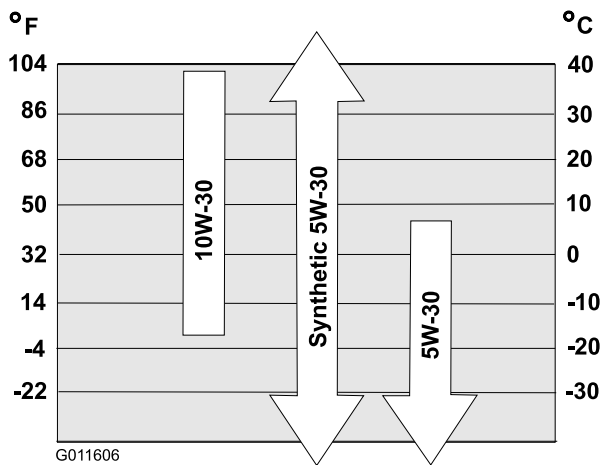

Figure 6

1. Move the machine to a level surface.
2. Clean around the oil-fill cap (Figure 11).
3. Unscrew the oil-fill cap and remove it.
4. **Slowly** pour oil into the oil-fill hole. Wait 3 minutes, then check the oil level on the dipstick by wiping the dipstick clean and then inserting, **but not screwing in**, the oil-fill cap into the hole.

**Note:** To determine the proper oil level on the dipstick, refer to Figure 7.

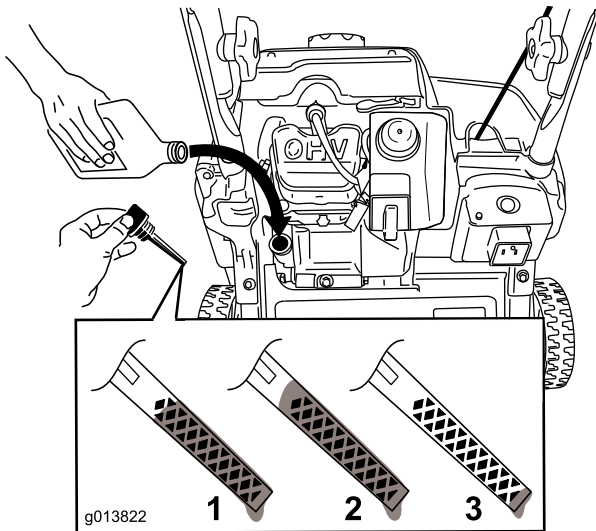

Figure 7

- |   |   |
|---|---|
| 1. The oil level is at its maximum.                         | 3. The oil level is too low—add oil to the crankcase. |
| 2. The oil level is too high—remove oil from the crankcase. |   |

**Note:** Fill the engine crankcase with oil until the dipstick indicates that the engine-oil level is correct as shown in Figure 7. If you overfill the engine with oil, remove the excess oil as directed in (page ).

**Note:** You may tip the machine forward (handle up) a little to make adding oil easier. Remember to return the machine to the operating position before checking the oil level.

**Important:** Do not tip the machine all the way forward onto its nose, or fuel may leak out of the machine.

5. Screw the oil fill cap into the oil-fill hole and hand tighten it securely.

# 5

## Adjusting the Control Cable

No Parts Required

### Checking the Control Cable

**Service Interval:** After the first hour—Check the control cable and adjust it if necessary.

Yearly—Check the control cable and adjust it if necessary.

**Important:** You must check and may need to adjust the control cable before you operate the machine for the first time.

Move the control bar back toward the handle to remove the slack in the control cable (Figure 8).

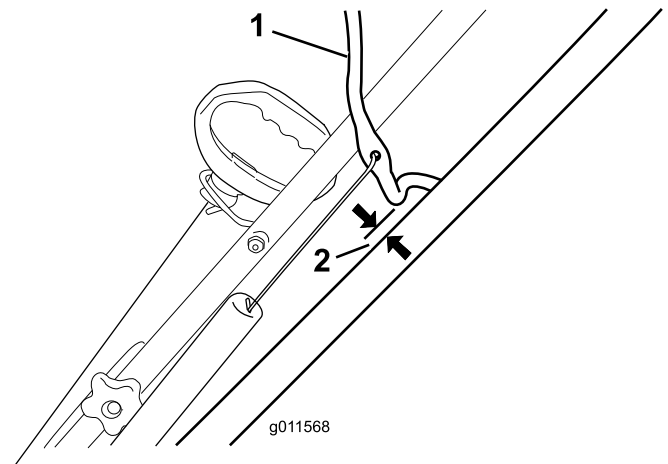

Figure 8

- |                |                                 |
|----------------|---------------------------------|
| 1. Control bar | 2. 2 to 3 mm (1/16 to 1/8 inch) |
|----------------|---------------------------------|

**Note:** Ensure that a gap of 2 to 3 mm (1/16 to 1/8 inch) exists between the control bar and the handle (Figure 8).

**Important:** The control cable must contain some slack when you disengage the control bar for the rotor blades to stop properly.

## Adjusting the Control Cable

- Slide up the spring cover and unhook the spring from the adjuster link (Figure 9).

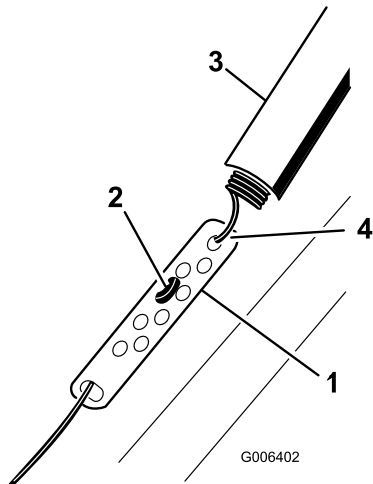

Figure 9

- |                  |                            |
|------------------|----------------------------|
| 1. Adjuster link | 3. Spring cover            |
| 2. Z-fitting     | 4. Unhook the spring here. |

**Note:** You can pull up the adjuster link and cable to make unhooking the spring easier.

- Move the Z-fitting to a higher or lower hole on the adjuster link as needed to obtain the 2 to 3 mm (1/16 to 1/8 inch) gap between the control bar and the handle (Figure 9).

**Note:** Moving the Z-fitting higher decreases the gap between the control bar and the handle; moving it lower increases the gap.

- Hook the spring to the adjuster link and slide the spring cover over the adjuster link.
- Check the adjustment; refer to [Checking the Control Cable](#) (page 6).

**Note:** The belt may slip (squeal) in wet conditions; to dry out the drive system, start the rotor and run it without a load for 30 seconds.

## Product Overview

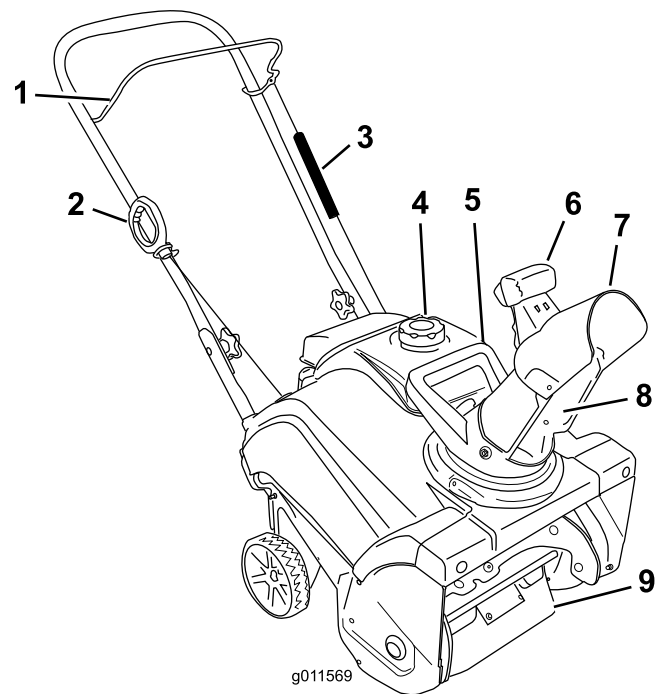

Figure 10

- |                        |                            |
|------------------------|----------------------------|
| 1. Control bar         | 6. Chute-deflector trigger |
| 2. Recoil-start handle | 7. Chute deflector         |
| 3. Spring cover        | 8. Discharge chute         |
| 4. Fuel-tank cap       | 9. Rotor blades            |
| 5. Chute handle        |                            |

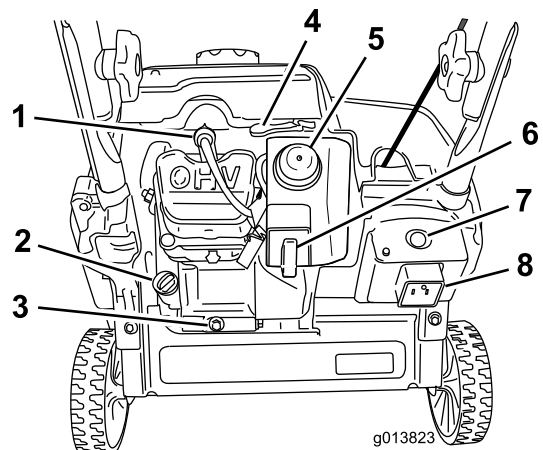

Figure 11

- |                   |  |
|-------------------|--|
| 1. Spark plug     | 5. Primer  |
| 2. Oil fill cap   | 6. Ignition key                                  |
| 3. Oil drain plug | 7. Electric-start button (Model 38473 only)      |
| 4. Choke lever    | 8. Plug-in for electric start (Model 38473 only) |

# Operation

**Note:** Determine the left and right sides of the machine from the normal operating position.

## Before Operation

### Safety

- Use extension cords and receptacles as specified by the manufacturer for all machines with electric starting motors.
- Do not operate the machine without wearing adequate winter garments. Avoid loose fitting clothing that can get caught in moving parts. Wear slip resistant footwear that will improve footing on slippery surfaces.
- Always wear safety glasses or eye shields during operation or while performing an adjustment or repair to protect eyes from foreign objects that may be thrown from the machine.
- Thoroughly inspect the area where the machine is to be used and remove all doormats, sleds, boards, wires, and other foreign objects.
- If a shield, safety device, or decal is damaged, illegible, or lost, repair or replace it before beginning operation. Also, tighten any loose fasteners.

## Filling the Fuel Tank

### **⚠ DANGER**

Gasoline is extremely flammable and explosive. A fire or explosion from gasoline can burn you and others.

- **To prevent a static charge from igniting the gasoline, place the container and/or machine on the ground before filling, not in a vehicle or on an object.**
- **Fill the tank outdoors when the engine is cold. Wipe up spills.**
- **Do not handle gasoline when smoking or around an open flame or sparks.**
- **Store gasoline in an approved fuel container, out of the reach of children.**
- For best results, use only clean, fresh, unleaded gasoline with an octane rating of 87 or higher ((R+M)/2 rating method).
- Oxygenated fuel with up to 10% ethanol or 15% MTBE by volume is acceptable.

- **Do not** use ethanol blends of gasoline (such as E15 or E85) with more than 10% ethanol by volume. Performance problems and/or engine damage may result which may not be covered under warranty.
- **Do not** use gasoline containing methanol.
- **Do not** store fuel either in the fuel tank or fuel containers over the winter unless a fuel stabilizer is used.
- **Do not** add oil to gasoline.

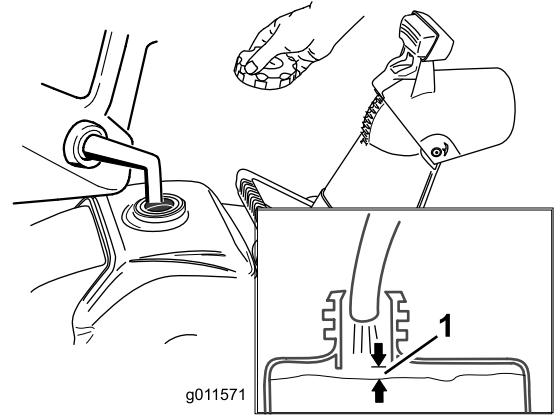

**Figure 12**

1. 13 mm (1/2 inch)

**Note:** For best results, purchase only the quantity of gasoline that you expect to use in 30 days. Otherwise, you may add fuel stabilizer to newly purchased gasoline to keep it fresh for up to 6 months.

## Checking the Engine-Oil Level

**Service Interval:** Before each use or daily—Check the engine oil level and add oil if necessary.

1. Ensure that the fuel tank is not overfilled (refer to [Figure 12](#)) and that the fuel cap is securely in place.
2. Move the machine to a level surface.
3. Clean around the oil-fill cap ([Figure 11](#)).
4. Unscrew the oil-fill cap and remove it.
5. Wipe the dipstick on the oil-fill cap with a clean cloth.
6. Insert, **but do not screw in**, the oil-fill cap into the oil-fill hole.
7. Remove the oil-fill cap and check the dipstick.
8. To determine the proper oil level on the dipstick, refer to [Figure 13](#).



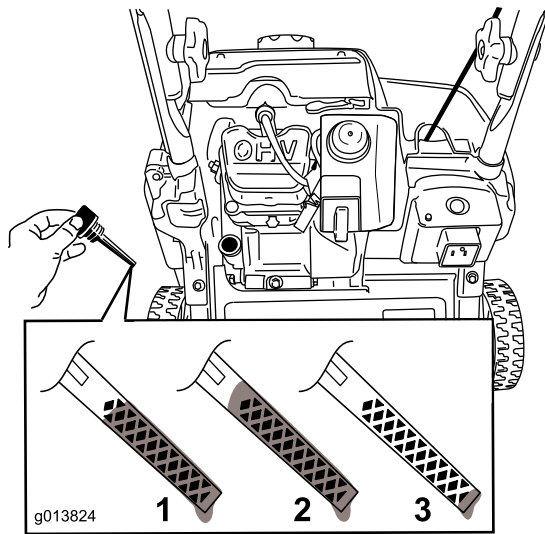

Figure 13

1. The oil level is at its maximum.
  2. The oil level is too high—remove oil from the crankcase.
  3. The oil level is too low—add oil to the crankcase.
- 
9. If the oil level is low, **slowly** pour oil into the oil-fill hole. Wait 3 minutes, then check the oil level on the dipstick by wiping the dipstick clean and then inserting, **but not screwing in**, the oil-fill cap into the hole.

**Note:** You may tip the machine forward (handle up) a little to make adding oil easier. Remember to return the machine to the operating position before checking the oil level.

**Important:** Do not tip the machine all the way forward onto its nose, or fuel may leak out of the machine.

Max fill: 0.35 L (12 oz), type: automotive detergent oil with an API service classification of SJ, SL, or higher.

Use [Figure 14](#) to select the best oil viscosity for the outdoor temperature range expected:

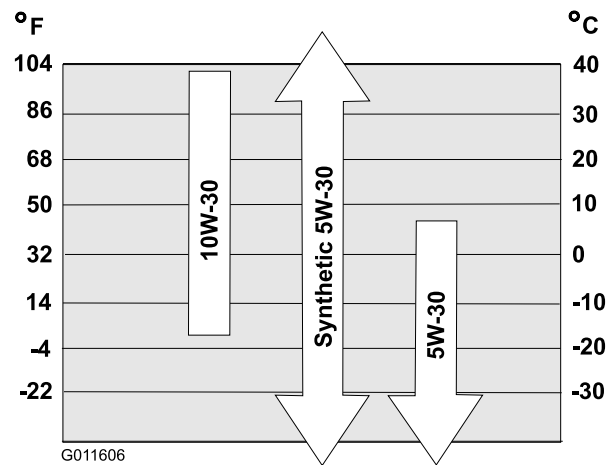

Figure 14

**Note:** Fill the engine crankcase with oil until the dipstick indicates that the engine oil level is correct as shown in [Figure 13](#). If you overfill the engine with oil, remove the excess oil as directed in [\(page \)](#).

10. Screw the oil-fill cap into the oil-fill hole and hand tighten it securely.

## During Operation

### Safety

- **Rotating rotor blades can injure fingers or hands.** Stay behind the handles and away from the discharge opening while operating the machine. **Keep your face, hands, feet, and any other part of your body or clothing away from moving or rotating parts.**
- Never direct the discharge toward people or areas where property damage can occur.
- Exercise caution to avoid slipping or falling. Always be sure of your footing, and keep a firm hold on the handles. Walk; never run.
- Exercise extreme caution when operating on slopes.
- Never operate the machine without good visibility or light.
- Look behind and use care when backing up with the machine.
- When not actively clearing snow, disengage power to the rotor blades.
- Use extension cords and receptacles as specified by the manufacturer for all machines with electric starting motors.
- Do not attempt to clear snow from a gravel or crushed rock surface. This product is intended for use only on paved surfaces.
- Do not use the machine on a roof.

- Never attempt to make any adjustments while the engine is running (except when specifically recommended by manufacturer).
- Stay alert for hidden hazards or traffic.
- After striking a foreign object, stop the engine, remove the ignition key, thoroughly inspect the machine for any damage, and repair the damage before restarting and operating the machine.
- If the machine should start to vibrate abnormally, stop the engine and check immediately for the cause.
- Do not run the engine indoors, except when starting the engine and for transporting the machine in or out of the building. Open the outside doors; exhaust fumes are dangerous.
- Do not overload the machine capacity by attempting to clear snow at too fast a rate.
- Never touch a hot engine or muffler.
- Thoroughly inspect the electrical cord before plugging it into a power source. If the cord is damaged, do not use it to start the machine. Replace the damaged cord immediately. Unplug the power cord whenever you are not starting the machine.

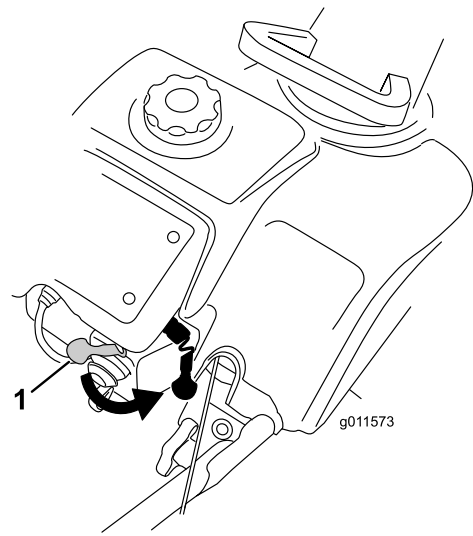

**Figure 16**

1. Choke lever

3. Firmly push in the primer 2 times with your thumb, holding the primer in for a second before releasing it each time (Figure 17).

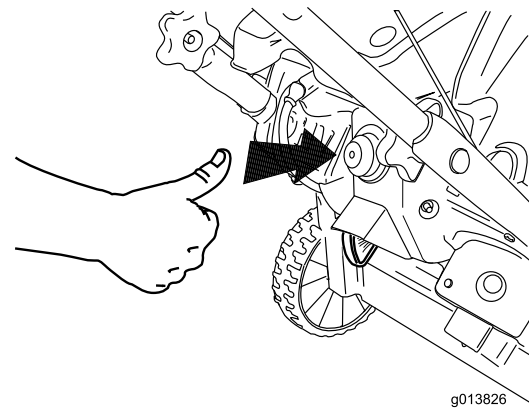

**Figure 17**

**Note:** Remove your glove when you push in the primer so that air cannot escape from the primer hole.

**Important:** Do not use the primer or the choke if the engine has been running and is hot. Excessive priming may flood the engine and prevent it from starting.

4. Connect an extension cord to a power source and the machine, and push the electric-start button (Model 38473 only) (Figure 18), or pull the recoil-start handle (Figure 19).

## Starting the Engine

1. Push the ignition key fully inward to the ON position (Figure 15).

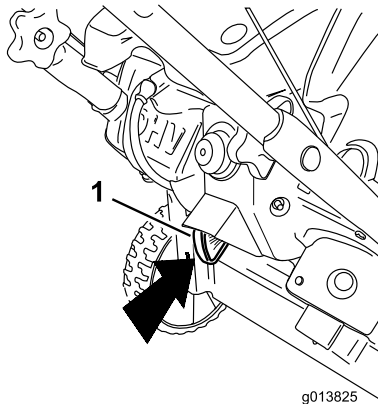

**Figure 15**

1. Ignition key

2. Move the choke lever fully to the right (Figure 16).

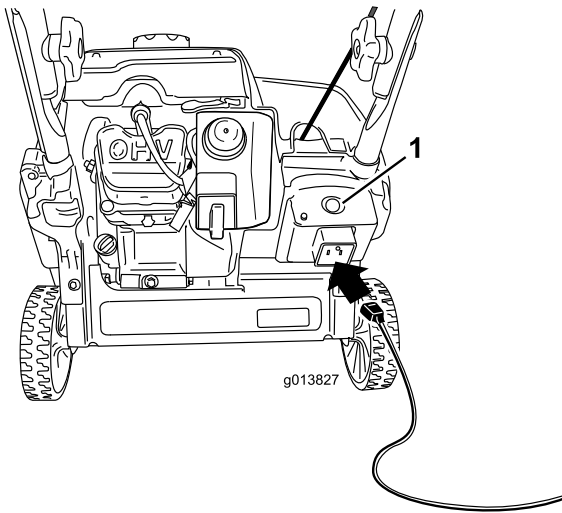

Figure 18

1. Electric-start button

**Note:** Use only a UL-listed, 16-gauge extension cord recommended for outdoor use that is not longer than 15 m (50 feet).

### ⚠ WARNING

The electrical cord can become damaged, causing a shock or fire.

Thoroughly inspect the electrical cord before plugging it into a power source. If the cord is damaged, do not use it to start the machine. Replace or repair the damaged cord immediately. Contact an Authorized Service Dealer for assistance.

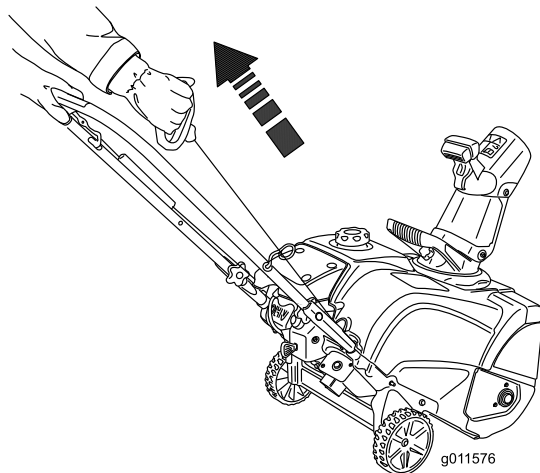

Figure 19

**Important:** Run the electric starter no more than 10 times at intervals of 5 seconds on, then 5 seconds off. Running the electric starter extensively can overheat and damage it. If the engine does not start after this series of attempts,

wait at least 40 minutes to allow the starter to cool before attempting to start it again. If the engine does not start after the second series of attempts, take the machine to an Authorized Service Dealer for service (Model 38473 only).

**Note:** If the recoil starter does not operate properly, it may be frozen. Thaw out the starter before attempting to start the machine.

5. While the engine is running, move the choke lever gradually to the left.
6. Unplug the extension cord from the power source and the machine (Model 38473 only).

### ⚠ CAUTION

If you leave the machine plugged into a power source, someone can inadvertently start the machine and injure people or damage property (model 38473 only).

Unplug the power cord whenever you are not starting the machine.

## Engaging the Rotor Blades

To engage the rotor blades, hold the control bar against the handle (Figure 20).

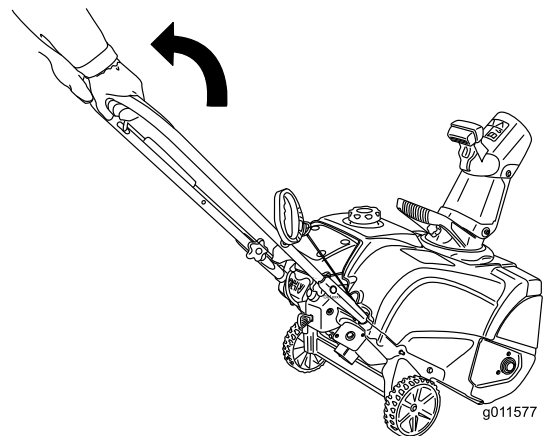

Figure 20

1. Control bar

## Disengaging the Rotor Blades

To disengage the rotor blades, release the control bar (Figure 21).

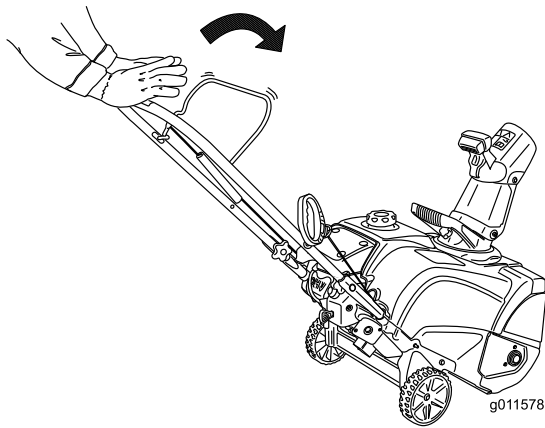

Figure 21

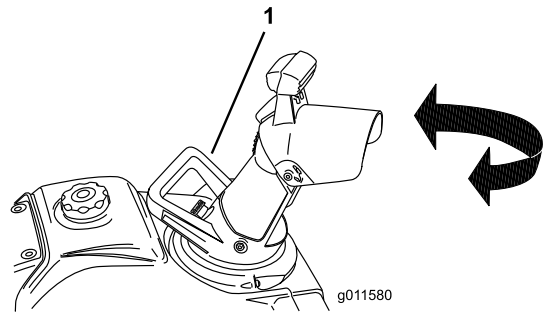

Figure 23

1. Chute handle

To raise or lower the angle of the chute deflector, press the trigger on the chute deflector and move the chute deflector up or down (Figure 24). Release the trigger to lock the chute deflector in place.

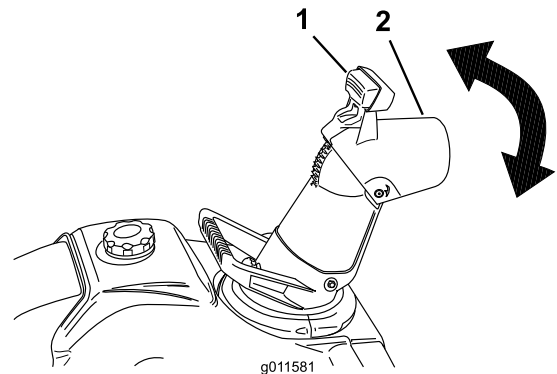

Figure 24

1. Trigger
2. Chute deflector

## Stopping the Engine

To stop the engine, pull the ignition key outward until it clicks into the OFF position (Figure 22) or move the choke lever fully to the right (Figure 16).

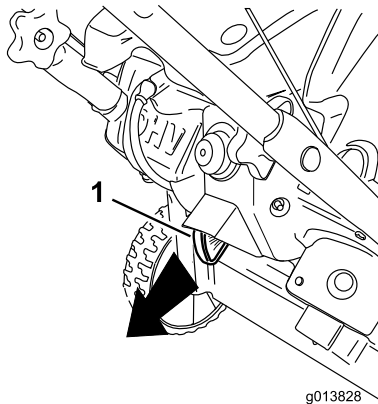

Figure 22

1. Ignition key

## Adjusting the Discharge Chute and Chute Deflector

To adjust the discharge chute, move the chute handle as shown in Figure 23.

## Clearing a Clogged Discharge Chute

To clear the chute:

- **Shut the engine off!**
- Wait 10 seconds to be sure the rotor blades have stopped rotating.
- Always use a clean-out tool; never use your hands.

## Self-propelling the Snowthrower

Lift the machine handle until the wheels are just off the ground and the scraper and rotor blades touch the ground. The machine will propel forward (Figure 25).

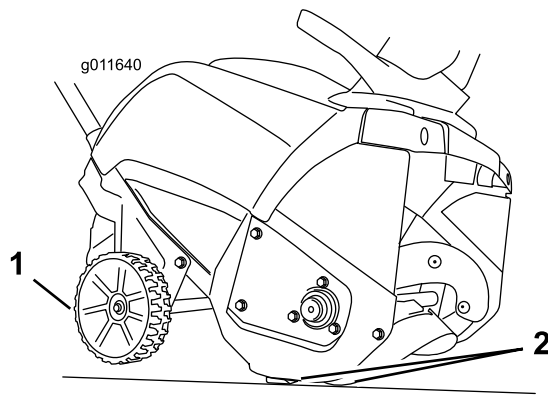

**Figure 25**

1. Wheels off the ground
2. Scraper and rotor blades in contact with the ground

**Note:** By slightly varying lifting force on the handle, you can control the forward speed of the machine. In heavy snow, push forward on the handle, if necessary, but let the machine work at its own pace. Do not lift the handle any more than necessary, because the scraper will lift off the ground and snow will escape behind the machine.

## Operating Tips

### **⚠ WARNING**

The rotor blades can throw stones, toys, and other foreign objects and cause serious personal injury to the operator or to bystanders.

- Keep the area to be cleared free of all objects that the rotor blades could pick up and throw.
- Keep all children and pets away from the area of operation.
- Remove the snow as soon as possible after it falls.
- Overlap each swath to ensure complete snow removal.
- Discharge the snow downwind whenever possible.

## After Operation

### Safety

- Never store the machine with fuel in the fuel tank inside a building where ignition sources are present, such as hot water heaters, space heaters, or clothes dryers. Allow the engine to cool before storing in any enclosure.
- When storing the machine for more than 30 days, refer to the Storage section for important details.

## Preventing Freeze-up after Use

- Let the engine run for a few minutes to prevent moving parts from freezing. Stop the engine, wait for all moving parts to stop, and remove ice and snow from the machine.

- Clean off any snow and ice from the base of the chute.
- Rotate the discharge chute left and right to free it from any ice buildup.
- With the ignition key in the OFF position, pull the recoil starter handle several times or connect the electrical cord to a power source and the machine and push the electric start button once (Model 38473 only) to prevent the recoil starter and/or the electric starter from freezing up.
- In snowy and cold conditions, some controls and moving parts may freeze. Do not use excessive force when trying to operate frozen controls. If you have difficulty operating any control or part, start the engine and let it run for a few minutes.

# Maintenance

**Note:** Determine the left and right sides of the machine from the normal operating position.

## Recommended Maintenance Schedule(s)

Maintenance Service Interval	Maintenance Procedure
After the first hour	<ul style="list-style-type: none"> <li>• Check the control cable and adjust it if necessary.</li> <li>• Check for loose fasteners and tighten them if necessary.</li> </ul>
After the first 2 hours	<ul style="list-style-type: none"> <li>• Change the engine oil.</li> </ul>
Before each use or daily	<ul style="list-style-type: none"> <li>• Check the engine oil level and add oil if necessary.</li> </ul>
Yearly	<ul style="list-style-type: none"> <li>• Check the control cable and adjust it if necessary.</li> <li>• Inspect the rotor blades and have an Authorized Service Dealer replace the rotor blades and scraper if necessary.</li> <li>• Change the engine oil.</li> <li>• Service the spark plug and replace it if necessary.</li> <li>• Check for loose fasteners and tighten them if necessary.</li> <li>• Have an Authorized Service Dealer inspect the drive belt and replace it if necessary.</li> </ul>
Yearly or before storage	<ul style="list-style-type: none"> <li>• Prepare the machine for storage.</li> </ul>

## Maintenance Safety

Read the following safety precautions before performing any maintenance on the machine:

- Before performing any maintenance, service, or adjustment, stop the engine and remove the key. If major repairs are ever needed, contact an Authorized Service Dealer.
- Check all fasteners at frequent intervals for proper tightness to be sure the machine is in safe working condition.
- Maintain or replace safety and instruction labels, as necessary.
- Do not change the governor settings on the engine.
- Purchase only genuine Toro replacement parts and accessories.

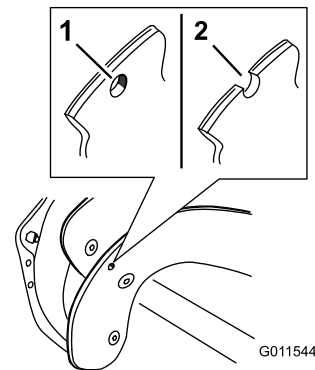

**Figure 26**

1. The wear indicator hole is intact; you do not need to replace the rotor blades.
2. The wear indicator hole is exposed; replace the rotor blades and scraper.
3. Scraper

## Adjusting the Control Cable

Refer to [5 Adjusting the Control Cable \(page 6\)](#).

## Inspecting the Rotor Blades

**Service Interval:** Yearly—Inspect the rotor blades and have an Authorized Service Dealer replace the rotor blades and scraper if necessary.

Before each session, inspect the rotor blades for wear. When a rotor blade edge has worn down to the wear indicator hole, have an Authorized Service Dealer replace the rotor blades and the scraper ([Figure 26](#)).

## Changing the Engine Oil

**Service Interval:** After the first 2 hours

Yearly

Run the engine a few minutes before changing the oil to warm it. Warm oil flows better and carries more contaminants.

1. Ensure that the fuel tank is not overfilled (refer to [Figure 12](#)) and that the fuel cap is securely in place.
2. Move the machine to a level surface.
3. Place an oil drain pan under the oil drain plug ([Figure 11](#)), remove the oil drain plug, and tip the machine

backward (handle down) halfway to the ground to drain the used oil into the oil drain pan.

**Important:** Do not tip the machine all the way back to the ground, or fuel may leak out of the machine.

- After draining the used oil, return the machine to the operating position.
- Install the oil-drain plug and tighten it securely.
- Clean around the oil-fill cap (Figure 11).
- Unscrew the oil-fill cap and remove it.
- Slowly** pour oil into the oil-fill hole. Wait 3 minutes, then check the oil level on the dipstick by wiping the dipstick clean and then inserting, **but not screwing in**, the oil-fill cap into the hole.

**Note:** To determine the proper oil level on the dipstick, refer to Figure 27.

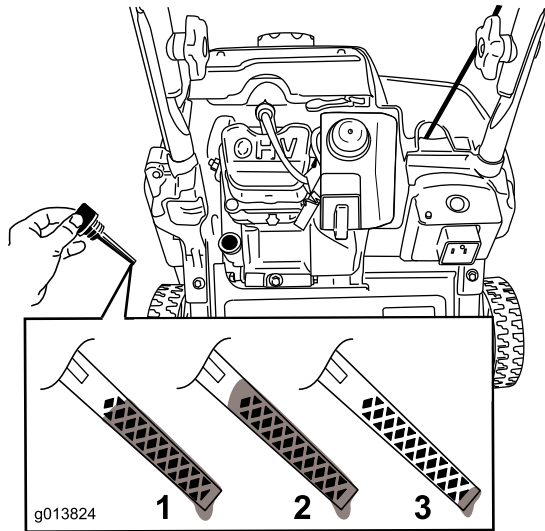

Figure 27

- The oil level is at its maximum.
- The oil level is too high—remove oil from the crankcase.
- The oil level is too low—add oil to the crankcase.

**Note:** You may tip the machine forward (handle up) a little to make adding oil easier. Remember to return the machine to the operating position before checking the oil level.

**Important:** Do not tip the machine all the way forward onto its nose, or fuel may leak out of the machine.

Max fill: 0.35 L (12 oz), type: automotive detergent oil with an API service classification of SJ, SL, or higher.

Use Figure 28 to select the best oil viscosity for the outdoor temperature range expected:

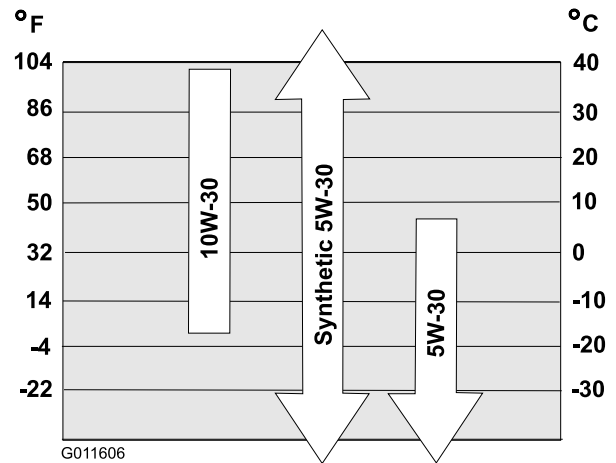

Figure 28

**Note:** Fill the engine crankcase with oil until the dipstick indicates that the engine oil level is correct as shown in Figure 27. If you overfill the engine with oil, remove the excess oil from the drain plug into an oil drain pan.

- Screw the oil-fill cap into the oil-fill hole, and hand tighten it securely.
- Wipe up any spilled oil.
- Dispose of the used oil properly at a local recycling center.

## Servicing the Spark Plug

**Service Interval:** Yearly—Service the spark plug and replace it if necessary.

Use a Toro spark plug (Part No. 119-1961).

- Stop the engine and wait for all moving parts to stop.
- Disconnect the wire from the spark plug (Figure 11).
- Clean around the spark plug.
- Remove the spark plug from the cylinder head.

**Important:** Replace a cracked, fouled, or dirty spark plug. Do not clean the electrodes because grit entering the cylinder can damage the engine.

- Set the gap on the plug to 0.76 mm (0.030 inch) (Figure 29).

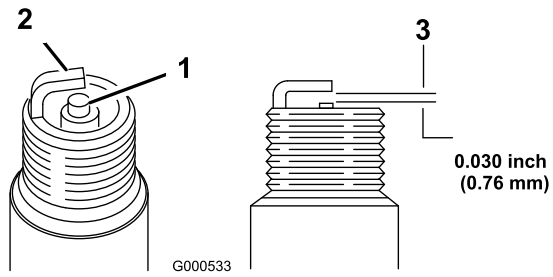

**Figure 29**

1. Center electrode insulator
2. Side electrode
3. Air gap (not to scale)

- 
6. Install the spark plug and torque it to 27–30 N-m (20–22 ft-lb).
  7. Connect the wire to the spark plug.



# Replacing the Drive Belt

If drive belt becomes worn, oil-soaked, excessively cracked, frayed, or otherwise damaged, replace the belt.

1. Remove the 4 bolts that hold the drive-belt cover (Figure 30) in place.

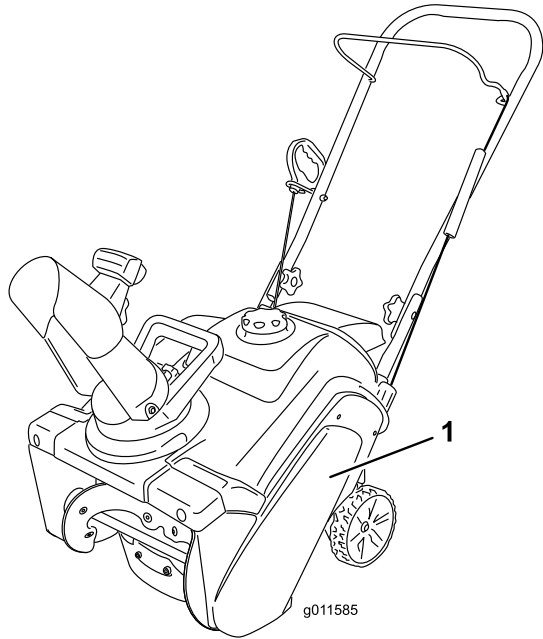

Figure 30

1. Drive belt cover

**Note:** The lower front corner of the drive belt cover is fastened down with a smaller bolt, a washer, and a locknut.

2. Remove the belt from the rotor pulley.

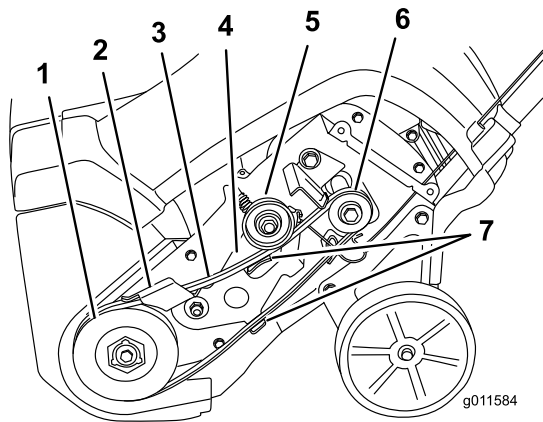

Figure 31

- |                    |                          |
|--------------------|--------------------------|
| 1. Rotor pulley    | 5. Idler pulley          |
| 2. Idler arm brake | 6. Engine pulley         |
| 3. Drive belt      | 7. Tabs on the idler arm |
| 4. Idler arm       |                          |

3. Press down on the idler arm and remove the belt from between the tab on the idler arm brake and the rotor pulley.

**Note:** The engine pulley belt guide is very close to the pulley, and the belt may not fit through the gap.

4. Twist the belt out in front of the belt guide so that the belt is wedged between the belt guide and the engine pulley.
5. Insert a screwdriver into the hole in the belt guide as shown in Figure 32, and flex the belt guide toward the rotor pulley enough to pull the belt through the gap.

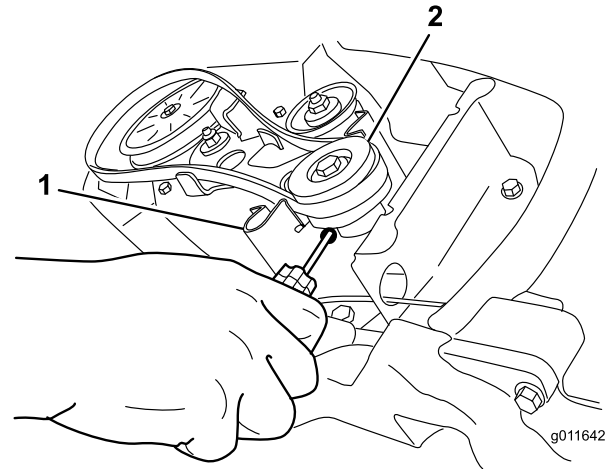

Figure 32

- |               |                  |
|---------------|------------------|
| 1. Belt guide | 2. Engine pulley |
|---------------|------------------|

**Note:** Take care not to distort or damage the belt guide.

6. To install the new drive belt, reverse the steps above.

**Important:** Ensure that you install the drive belt so that it sits above the 2 tabs on the idler arm and below the idler arm brake (Figure 31).

7. Install the drive belt cover with the fasteners that you removed in step 1.

# Storage

## Storing the Machine

### ▲ WARNING

- Gasoline fumes are highly flammable, explosive, and dangerous if inhaled. If you store the product in an area with an open flame, the gasoline fumes may ignite and cause an explosion.
- Do not store the machine in a house (living area), basement, or any other area where ignition sources may be present, such as hot water and space heaters, clothes dryers, furnaces, and other like appliances.
- Do not tip the machine either forward or backward with fuel in the fuel tank; otherwise, fuel may leak out of the machine.
- Do not store the machine with its handle tipped down onto the ground, because oil will leak into the engine cylinder and onto the ground, and the machine will not start or run.

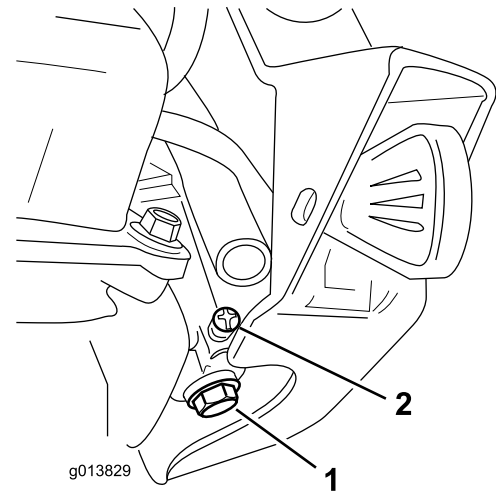

Figure 33

1. Carburetor bowl bolt—do not remove
2. Small screw on carburetor not remove

1. On the last refueling of the season, add fuel stabilizer to fresh fuel as directed by the engine manufacturer.
2. Run the engine for 10 minutes to distribute the conditioned fuel through the fuel system.
3. While the engine is still warm, change the engine oil. Refer to [Changing the Engine Oil \(page 14\)](#).
4. Drain the fuel from the tank and carburetor by performing the following steps:
  - A. Loosen the fuel-tank cap.
  - B. Unscrew, but do not remove, the small screw on the side of the carburetor fuel bowl ([Figure 33](#)) until the fuel begins to drain from the carburetor. Drain the fuel into an approved fuel container.

**Important:** Do not remove the carburetor bowl bolt on the bottom of the carburetor.

- C. Wait for a few minutes until the fuel has drained, then install the fuel cap and tighten the small screw on the carburetor.

**Note:** Use a handheld Phillips screwdriver to tighten the carburetor screw. Overtightening the screw could strip it and cause leaking.

5. Dispose of unused fuel properly. Recycle it according to local codes, or use it in your automobile.
6. Remove the spark plug.
7. Squirt 2 teaspoons of oil into the spark plug hole.
8. Install the spark plug by hand and then torque it to 27–30 N-m (20–22 ft-lb).
9. With the ignition key in the OFF position, pull the recoil starter slowly to distribute the oil on the inside of the cylinder.
10. Disconnect the ignition key from the lanyard and store the ignition key in a safe place.
11. Clean the machine.
12. Touch up chipped surfaces with paint available from an Authorized Service Dealer. Sand affected areas before painting, and use a rust preventative to prevent the metal parts from rusting.
13. Tighten any loose fasteners. Repair or replace any damaged parts.
14. Cover the machine and store it in a clean, dry place out of the reach of children. Allow the engine to cool before storing it in any enclosure.

**Notes:**

**Notes:**

**Notes:**



## Emission Control Warranty Statement

For the United States, California, and Canada



### Your Warranty Rights and Obligations

The California Air Resources Board (CARB), the U.S. Environmental Protection Agency (EPA), and The Toro Company, are pleased to explain the emission control system warranty on your 2015–2016 small off-road engine/equipment. In California and the United States, new small off-road engines/equipment must be designed, built, and certified to meet stringent anti-smog standards. The Toro Company warrants the emission control system on your small off-road engine/equipment for the period of time listed below, provided there has been no abuse, neglect, or improper maintenance of your small off-road engine/equipment.

Your emission control system may include parts such as the carburetor, fuel-injection system, the ignition system, catalytic converter, fuel tanks, fuel lines, fuel caps, valves, canisters, filters, vapor hoses, clamps, connectors, and other associated emission-related components.

Where a warrantable condition exists, The Toro Company will repair your small off-road engine/equipment at no cost to you including diagnosis, parts and labor.

### Manufacturer's Warranty Coverage

This emission control system is warranted for two years. If any emission-related part on your engine/equipment is defective, the part will be repaired or replaced by The Toro Company.

### Owner Responsibilities

As the small off-road engine owner, you are responsible for the performance of the required maintenance listed in your *Operator's Manual*. We recommend that you retain all receipts covering maintenance on your small off-road engine/equipment, but we cannot deny warranty solely for the lack of receipts.

As the small off-road engine/equipment owner, you should however be aware that we may deny you warranty coverage if your small off-road engine/equipment or a part has failed due to abuse, neglect, improper maintenance or unapproved modifications.

You are responsible for presenting your small off-road engine/equipment to a Toro Distribution Center or Service Center as soon as a problem exists. The warranty repairs should be completed in a reasonable amount of time, not to exceed thirty (30) days.

If you have any questions regarding your warranty coverage, contact us at:

Customer Care Department, Consumer Division  
Toro Warranty Company  
8111 Lyndale Avenue South  
Bloomington, MN 55420-1196  
1-952-948-4027 (U.S. and Canadian customers)  
email Customer Support at: [www.toro.com](http://www.toro.com)

### General Emissions Warranty Coverage

The Toro Company warrants to the ultimate purchaser and each subsequent purchaser that the small off-road engine/equipment is:

- Designed, built, and certified to conform with all applicable emissions regulations; and
- Free from defects in materials and workmanship that could cause the failure of a warranted part; and
- Identical in all material respects to the parts as described in the application for certification.

The warranty period begins on the date the small off-road engine/equipment is delivered to an ultimate purchaser. The warranted period is two years.

Subject to certain conditions and exclusions as stated below, the warranty on evaporative emissions-related parts is as follows:

1. Any warranted part that is not scheduled for replacement as required maintenance in the written instructions supplied, is warranted for the warranty period stated above. If the part fails during the period of warranty coverage, the part will be repaired or replaced by The Toro Company. Any such part repaired or replaced under warranty will be warranted for the remainder of the warranty period.
2. Any warranted part that is scheduled only for regular inspection in the written instructions supplied is warranted for the warranty period stated above. Any such part repaired or replaced under the warranty will be warranted for the remainder of the warranty period.
3. Any warranted part that is scheduled for replacement as required maintenance in the written instructions supplied is warranted for the period of time before the first scheduled replacement date for that part. If the part fails before the first scheduled replacement, the part will be repaired or replaced by The Toro Company. Any such part repaired or replaced under warranty will be warranted for the remainder of the period prior to the first scheduled replacement point for the part.
4. Repair or replacement of any warranted part under the warranty provisions herein must be performed at an Authorized Service Dealer at no charge to the owner.
5. Warranty services or repairs will be provided at all Service Dealers authorized to service the subject engines or equipment.
6. The small off-road engine/equipment owner will not be charged for diagnostic labor that is directly associated with diagnosis of a defective, emission-related warranted part, provided that such diagnostic work is performed at an Authorized Service Dealer.
7. The Toro Company is liable for damages to other engine/equipment components caused by a failure under warranty of any warranted part.
8. Throughout the small off-road engine/equipment warranty period stated above, The Toro Company will maintain a supply of warranted parts sufficient to meet the expected demand for such parts.
9. Manufacturer approved replacement parts may be used in the performance of any warranty maintenance or repairs and must be provided without charge to the owner. Such use will not reduce the warranty obligations of The Toro Company.
10. Add-on or modified parts that are not approved by The Toro Company may not be used. The use of a non-approved add-on or modified parts by the purchaser will be grounds for disallowing a warranty claim. The Toro Company will not be liable to warrant failures of warranted parts caused by the use of a non-approved add-on or modified parts.

### Warranted Parts

The following emission warranty parts are covered, to the extent these parts were present on the Toro engine/equipment and/or Toro supplied fuel system:

1. Fuel System Parts
  - Carburetor and internal parts
  - Cold starting enrichment (primer or choke)
  - Fuel pump
  - Fuel line, fittings, and clamps
  - Fuel tank, cap, and tether
  - Carbon canister
2. Air Induction System
  - Air cleaner
  - Intake manifold
  - Crankcase vent and line(s)
  - Purge line and fittings
3. Ignition System
  - Spark plug(s) and wire(s)
  - Magneto ignition system
4. Catalytic Exhaust System
  - Catalytic converter
  - Exhaust manifold
  - Air injector system and valve(s)
5. Miscellaneous Items Used in Emission Control System
  - Valves, switches, and linkages
  - Connectors, fittings, and brackets



# The Toro Warranty and The Toro 2-Year GTS Starting Guarantee

A Two-Year Full Warranty (45 Day Limited Warranty for Commercial Use)

Power Clear  
Single-Stage Snowthrowers

## The Toro Starting Guarantee

The Toro Company and its affiliate, Toro Warranty Company, pursuant to an agreement between them, jointly guarantee that your Toro GTS (Guaranteed to Start) engine, when used for residential purposes\*, will start on the first or second pull for two (2) years from the date of purchase, if you provide the routine maintenance it requires, or we will fix it free of charge. The GTS Starting Guarantee does not apply under commercial use.

This warranty covers the cost of parts and labor, but you must pay transportation costs.

## The Toro Total Coverage Guarantee

The Toro Company and its affiliate, Toro Warranty Company, pursuant to an agreement between them, jointly promise to repair the Toro Product listed below if used for residential purposes\*, if defective in materials or workmanship or if it stops functioning due to the failure of a component for the period listed below.

This warranty covers the cost of parts and labor, but you must pay transportation costs.

The following time periods apply from the original date of purchase:

Products	Warranty Period
Power Clear Snowthrowers and Attachments	2 years

## Limited Warranty for Commercial Use

Gas-powered Toro Products used for commercial, institutional, or rental use, are warranted for 45 days against defects in materials or workmanship. Components failing due to normal wear are not covered by this warranty.

## Instructions for Obtaining Warranty Service

If you think that your Toro Product contains a defect in materials or workmanship, follow this procedure:

1. Contact any Authorized Toro Service Dealer to arrange service at their dealership. To locate a dealer convenient to you, access our web site at [www.Toro.com](http://www.Toro.com). You may also call the numbers listed in item #3 to use the 24-hour Toro Dealer locator system.
2. Bring the product and your proof of purchase (sales receipt) to the Service Dealer. The dealer will diagnose the problem and determine if it is covered under warranty.
3. If for any reason you are dissatisfied with the Service Dealer's analysis or with the assistance provided, contact us at:

Toro Warranty Company  
Customer Care Department, RLC Division  
8111 Lyndale Avenue South  
Bloomington, MN 55420-1196  
Toll free at 866-336-5205 (U.S. customers)  
Toll free at 866-854-9033 (Canadian customers)

## Owner Responsibilities

You must maintain your Toro Product by following the maintenance procedures described in the *Operator's Manual*. Such routine maintenance, whether performed by a dealer or by you, is at your expense.

## Countries Other than the United States or Canada

Customers who have purchased Toro products exported from the United States or Canada should contact their Toro Distributor (Dealer) to obtain guarantee policies for your country, province, or state. If for any reason you are dissatisfied with your Distributor's service or have difficulty obtaining guarantee information, contact the Toro importer. If all other remedies fail, you may contact us at Toro Warranty Company.

**Australian Consumer Law:** Australian customers will find details relating to the Australian Consumer Law either inside the box or at your local Toro Dealer.

\*Residential purposes means use of the product on the same lot as your home. Use at more than one location, or institutional or rental use, is considered commercial use, and the commercial use warranty would apply.

## Items and Conditions Not Covered

There is no other express warranty except for special emission system coverage and engine warranty coverage on some products. This express warranty does not cover the following:

- Cost of regular maintenance or replacement of wear parts, such as rotor blades (paddles), scraper blades, belts, fuel, lubricants, oil changes, spark plugs, light bulbs, cable/linkage or brake adjustments
- Any product or part which has been altered or misused or requires replacement or repair due to accidents or lack of proper maintenance
- Pickup and delivery charges
- Operational misuse, neglect, or accidents
- Repairs or attempted repairs by anyone other than an Authorized Toro Service Dealer
- Repairs necessary due to failure to follow recommended fuel procedure (consult *Operator's Manual* for more details)
  - Removing contaminants from the fuel system is not covered
  - Use of old fuel (more than one month old) or fuel which contains more than 10% ethanol or more than 15% MTBE
  - Failure to drain the fuel system prior to any period of non-use over one month
- Repairs or adjustments to correct starting difficulties due to the following:
  - Failure to follow proper maintenance procedures
  - Snowthrower auger/paddles striking an object
  - Contaminants in the fuel system
  - Improper fuel (consult your *Operator's Manual* if in doubt)
  - Failure to drain the fuel system prior to any period of non-use over one month
- Special operational conditions where starting may require more than two pulls:
  - First time starts after extended period of non-use over three months or seasonal storage
  - Improper starting procedures
  - Starting in -10° F (-23° C) or below temperatures

If you are having difficulty starting your unit, please check the *Operator's Manual* to ensure that you are using the correct starting procedures. This can save an unnecessary visit to a Service Dealer.

## General Conditions

All repairs covered by these warranties must be performed by an Authorized Toro Service Dealer using Toro approved replacement parts. Repair by an Authorized Toro Service Dealer is your sole remedy under this warranty.

**Neither The Toro Company nor Toro Warranty Company is liable for indirect, incidental, or consequential damages in connection with the use of the Toro Products covered by these warranties, including any cost or expense of providing substitute equipment or service during reasonable periods of malfunction or non-use pending completion of repairs under these warranties.**

Some states do not allow exclusions of incidental or consequential damages, so the above exclusions may not apply to you.

This warranty gives you specific legal rights, and you may also have other rights which vary from state to state.